

74HC165; 74HCT165

8-bit parallel-in/serial out shift register

Rev. 03 — 14 March 2008

Product data sheet

1. General description

The 74HC165; 74HCT165 are high-speed Si-gate CMOS devices that comply with JEDEC standard no. 7A. They are pin compatible with Low-power Schottky TTL (LSTTL).

The 74HC165; 74HCT165 are 8-bit parallel-load or serial-in shift registers with complementary serial outputs (Q_7 and $\overline{Q_7}$) available from the last stage. When the parallel load (\overline{PL}) input is LOW, parallel data from the D0 to D7 inputs are loaded into the register asynchronously.

When \overline{PL} is HIGH, data enters the register serially at the DS input and shifts one place to the right ($Q_0 \rightarrow Q_1 \rightarrow Q_2$, etc.) with each positive-going clock transition. This feature allows parallel-to-serial converter expansion by tying the Q_7 output to the DS input of the succeeding stage.

The clock input is a gated-OR structure which allows one input to be used as an active LOW clock enable (\overline{CE}) input. The pin assignment for the CP and \overline{CE} inputs is arbitrary and can be reversed for layout convenience. The LOW-to-HIGH transition of input \overline{CE} should only take place while CP HIGH for predictable operation. Either the CP or the \overline{CE} should be HIGH before the LOW-to-HIGH transition of \overline{PL} to prevent shifting the data when \overline{PL} is activated.

2. Features

- Asynchronous 8-bit parallel load
- Synchronous serial input
- Complies with JEDEC standard no. 7A
- ESD protection:
 - ◆ HBM JESD22-A114E exceeds 2000 V
 - ◆ MM JESD22-A115-A exceeds 200 V
- Specified from $-40\text{ }^{\circ}\text{C}$ to $+85\text{ }^{\circ}\text{C}$ and from $-40\text{ }^{\circ}\text{C}$ to $+125\text{ }^{\circ}\text{C}$

3. Applications

- Parallel-to-serial data conversion

4. Ordering information

Table 1. Ordering information

Type number	Package			Version
	Temperature range	Name	Description	
74HC165N 74HCT165N	-40 °C to +125 °C	DIP16	plastic dual in-line package; 16 leads (300 mil)	SOT38-4
74HC165D 74HCT165D	-40 °C to +125 °C	SO16	plastic small outline package; 16 leads; body width 3.9 mm	SOT109-1
74HC165DB 74HCT165DB	-40 °C to +125 °C	SSOP16	plastic shrink small outline package; 16 leads; body width 5.3 mm	SOT338-1
74HC165PW 74HCT165PW	-40 °C to +125 °C	TSSOP16	plastic thin shrink small outline package; 16 leads; body width 4.4 mm	SOT403-1
74HC165BQ 74HCT165BQ	-40 °C to +125 °C	DHVQFN16	plastic dual in-line compatible thermal enhanced very thin quad flat package; no leads; 16 terminals; body 2.5 × 3.5 × 0.85 mm	SOT763-1

5. Functional diagram

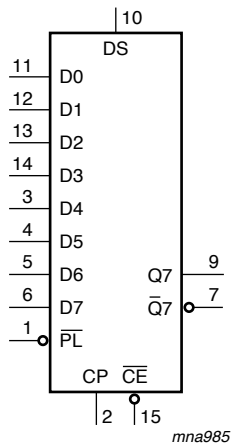

Fig 1. Logic symbol

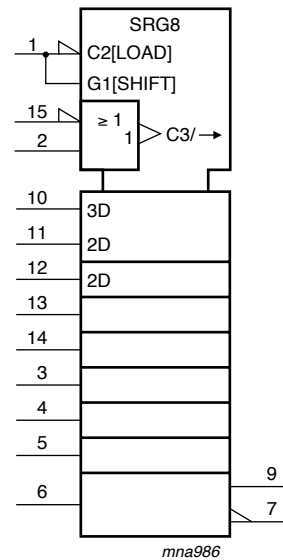

Fig 2. IEC logic symbol

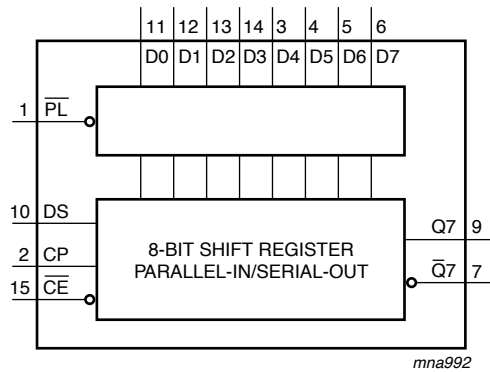

Fig 3. Functional diagram

6. Pinning information

6.1 Pinning

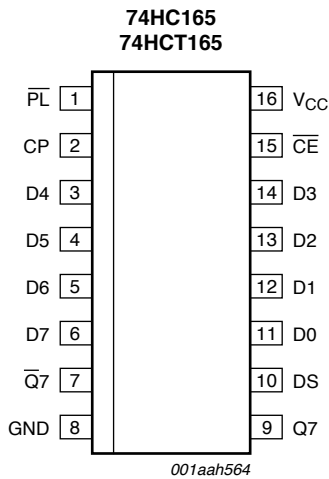
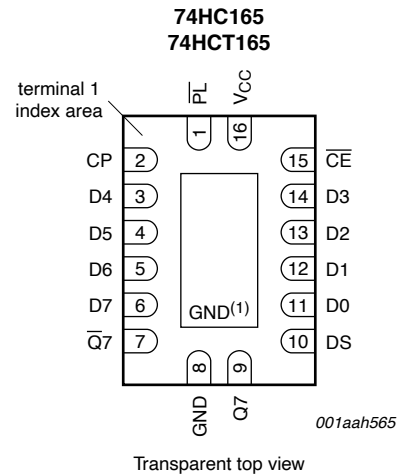

Fig 4. Pin configuration (DIP16, SO16 and (T)SSOP16)



- (1) The die substrate is attached to this pad using conductive die attach material. It can not be used as supply pin or input.

Fig 5. Pin configuration (DHVQFN16)

6.2 Pin description

Table 2. Pin description

Symbol	Pin	Description
\overline{PL}	1	asynchronous parallel load input (active LOW)
CP	2	clock input (LOW-to-HIGH edge-triggered)
$\overline{Q7}$	7	complementary output from the last stage
GND	8	ground (0 V)
Q7	9	serial output from the last stage
DS	10	serial data input
D0 to D7	11, 12, 13, 14, 3, 4, 5, 6	parallel data inputs (also referred to as Dn)
\overline{CE}	15	clock enable input (active LOW)
V _{CC}	16	positive supply voltage

7. Functional description

Table 3. Function table^[1]

Operating modes	Inputs					Qn registers		Outputs	
	\overline{PL}	\overline{CE}	CP	DS	D0 to D7	Q0	Q1 to Q6	Q7	$\overline{Q7}$
parallel load	L	X	X	X	L	L	L to L	L	H
	L	X	X	X	H	H	H to H	H	L
serial shift	H	L	↑	l	X	L	q0 to q5	q6	$\overline{q6}$
	H	L	↑	h	X	H	q0 to q5	q6	$\overline{q6}$
	H	↑	L	l	X	L	q0 to q5	q6	$\overline{q6}$
	H	↑	L	h	X	H	q0 to q5	q6	$\overline{q6}$
hold "do nothing"	H	H	X	X	X	q0	q1 to q6	q7	$\overline{q7}$
	H	X	H	X	X	q0	q1 to q6	q7	$\overline{q7}$

[1] H = HIGH voltage level;
 h = HIGH voltage level one set-up time prior to the LOW-to-HIGH clock transition;
 L = LOW voltage level;
 l = LOW voltage level one set-up time prior to the LOW-to-HIGH clock transition;
 q = state of the referenced output one set-up time prior to the LOW-to-HIGH clock transition;
 X = don't care;
 ↑ = LOW-to-HIGH clock transition.

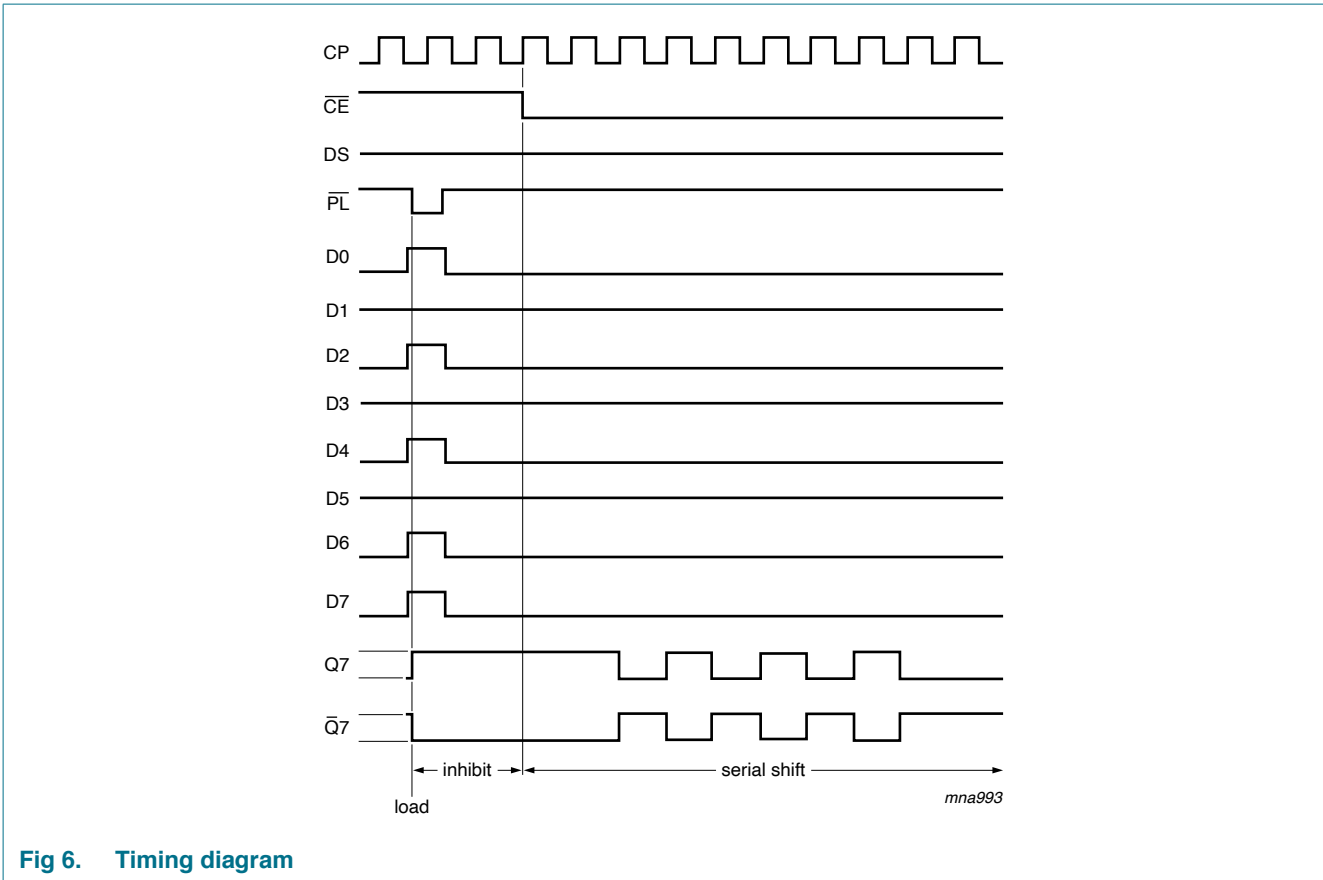

Fig 6. Timing diagram

8. Limiting values

Table 4. Limiting values

In accordance with the Absolute Maximum Rating System (IEC 60134). Voltages are referenced to GND (ground = 0 V)

Symbol	Parameter	Conditions	Min	Max	Unit
V_{CC}	supply voltage		-0.5	+7	V
I_{IK}	input clamping current	$V_I < -0.5\text{ V}$ or $V_I > V_{CC} + 0.5\text{ V}$	[1] -	±20	mA
I_{OK}	output clamping current	$V_O < -0.5\text{ V}$ or $V_O > V_{CC} + 0.5\text{ V}$	[1] -	±20	mA
I_O	output current	$-0.5\text{ V} < V_O < V_{CC} + 0.5\text{ V}$	-	±25	mA
I_{CC}	supply current		-	50	mA
I_{GND}	ground current		-50	-	mA
T_{stg}	storage temperature		-65	+150	°C

Table 4. Limiting values ...continued

In accordance with the Absolute Maximum Rating System (IEC 60134). Voltages are referenced to GND (ground = 0 V)

Symbol	Parameter	Conditions	Min	Max	Unit	
P _{tot}	total power dissipation	T _{amb} = -40 °C to +125 °C				
		DIP16 package	[2]	-	750	mW
		SO16 package	[3]	-	500	mW
		(T)SSOP16 package	[4]	-	500	mW
		DHVQFN16 package	[5]	-	500	mW

[1] The input and output voltage ratings may be exceeded if the input and output current ratings are observed.

[2] P_{tot} derates linearly with 12 mW/K above 70 °C.

[3] P_{tot} derates linearly with 8 mW/K above 70 °C.

[4] P_{tot} derates linearly with 5.5 mW/K above 60 °C.

[5] P_{tot} derates linearly with 4.5 mW/K above 60 °C.

9. Recommended operating conditions

Table 5. Recommended operating conditions

Voltages are referenced to GND (ground = 0 V)

Symbol	Parameter	Conditions	74HC165			74HCT165			Unit
			Min	Typ	Max	Min	Typ	Max	
V _{CC}	supply voltage		2.0	5.0	6.0	4.5	5.0	5.5	V
V _I	input voltage		0	-	V _{CC}	0	-	V _{CC}	V
V _O	output voltage		0	-	V _{CC}	0	-	V _{CC}	V
T _{amb}	ambient temperature		-40	-	+125	-40	-	+125	°C
Δt/ΔV	input transition rise and fall rate	V _{CC} = 2.0 V	-	-	625	-	-	-	ns/V
		V _{CC} = 4.5 V	-	1.67	139	-	1.67	139	ns/V
		V _{CC} = 6.0 V	-	-	83	-	-	-	ns/V

10. Static characteristics

Table 6. Static characteristics

At recommended operating conditions; voltages are referenced to GND (ground = 0 V).

Symbol	Parameter	Conditions	25 °C			-40 °C to +85 °C		-40 °C to +125 °C		Unit
			Min	Typ	Max	Min	Max	Min	Max	
74HC165										
V _{IH}	HIGH-level input voltage	V _{CC} = 2.0 V	1.5	1.2	-	1.5	-	1.5	-	V
		V _{CC} = 4.5 V	3.15	2.4	-	3.15	-	3.15	-	V
		V _{CC} = 6.0 V	4.2	3.2	-	4.2	-	4.2	-	V
V _{IL}	LOW-level input voltage	V _{CC} = 2.0 V	-	0.8	0.5	-	0.5	-	0.5	V
		V _{CC} = 4.5 V	-	2.1	1.35	-	1.35	-	1.35	V
		V _{CC} = 6.0 V	-	2.8	1.8	-	1.8	-	1.8	V

Table 6. Static characteristics ...continued

At recommended operating conditions; voltages are referenced to GND (ground = 0 V).

Symbol	Parameter	Conditions	25 °C			-40 °C to +85 °C		-40 °C to +125 °C		Unit
			Min	Typ	Max	Min	Max	Min	Max	
V _{OH}	HIGH-level output voltage	V _I = V _{IH} or V _{IL}								
		I _O = -20 μA; V _{CC} = 2.0 V	1.9	2.0	-	1.9	-	1.9	-	V
		I _O = -20 μA; V _{CC} = 4.5 V	4.4	4.5	-	4.4	-	4.4	-	V
		I _O = -20 μA; V _{CC} = 6.0 V	5.9	6.0	-	5.9	-	5.9	-	V
		I _O = -4.0 mA; V _{CC} = 4.5 V	3.98	4.32	-	3.84	-	3.7	-	V
		I _O = -5.2 mA; V _{CC} = 6.0 V	5.48	5.81	-	5.34	-	5.2	-	V
V _{OL}	LOW-level output voltage	V _I = V _{IH} or V _{IL}								
		I _O = 20 μA; V _{CC} = 2.0 V	-	0	0.1	-	0.1	-	0.1	V
		I _O = 20 μA; V _{CC} = 4.5 V	-	0	0.1	-	0.1	-	0.1	V
		I _O = 20 μA; V _{CC} = 6.0 V	-	0	0.1	-	0.1	-	0.1	V
		I _O = 4.0 mA; V _{CC} = 4.5 V	-	0.15	0.26	-	0.33	-	0.4	V
		I _O = 5.2 mA; V _{CC} = 6.0 V	-	0.16	0.26	-	0.33	-	0.4	V
I _I	input leakage current	V _I = V _{CC} or GND; V _{CC} = 6.0 V	-	-	±0.1	-	±1	-	±1	μA
I _{CC}	supply current	V _I = V _{CC} or GND; I _O = 0 A; V _{CC} = 6.0 V	-	-	8.0	-	80	-	160	μA
C _I	input capacitance		-	3.5	-	-	-	-	-	pF
74HCT165										
V _{IH}	HIGH-level input voltage	V _{CC} = 4.5 V to 5.5 V	2.0	1.6	-	2.0	-	2.0	-	V
V _{IL}	LOW-level input voltage	V _{CC} = 4.5 V to 5.5 V	-	1.2	0.8	-	0.8	-	0.8	V
V _{OH}	HIGH-level output voltage	V _I = V _{IH} or V _{IL} ; V _{CC} = 4.5 V								
		I _O = -20 μA	4.4	4.5	-	4.4	-	4.4	-	V
		I _O = -4.0 mA	3.98	4.32	-	3.84	-	3.7	-	V
V _{OL}	LOW-level output voltage	V _I = V _{IH} or V _{IL} ; V _{CC} = 4.5 V								
		I _O = 20 μA; V _{CC} = 4.5 V	-	0	0.1	-	0.1	-	0.1	V
		I _O = 5.2 mA; V _{CC} = 6.0 V	-	0.16	0.26	-	0.33	-	0.4	V
I _I	input leakage current	V _I = V _{CC} or GND; V _{CC} = 6.0 V	-	-	±0.1	-	±1	-	±1	μA
I _{CC}	supply current	V _I = V _{CC} or GND; I _O = 0 A; V _{CC} = 6.0 V	-	-	8.0	-	80	-	160	μA
ΔI _{CC}	additional supply current	per input pin; V _I = V _{CC} - 2.1 V; other inputs at V _{CC} or GND; V _{CC} = 4.5 V to 5.5 V								
		Dn and DS inputs	-	35	126	-	157.5	-	171.5	μA
		CP \overline{CE} , and \overline{PL} inputs	-	65	234	-	292.5	-	318.5	μA
C _I	input capacitance		-	3.5	-	-	-	-	-	pF

11. Dynamic characteristics

Table 7. Dynamic characteristics

GND (ground = 0 V); $C_L = 50$ pF unless otherwise specified; for test circuit, see [Figure 12](#)

Symbol	Parameter	Conditions	25 °C			-40 °C to +85 °C		-40 °C to +125 °C		Unit
			Min	Typ	Max	Min	Max	Min	Max	
74HC165										
t_{pd}	propagation delay	CP or \overline{CE} to Q7, $\overline{Q7}$; see Figure 7	[1]							
		$V_{CC} = 2.0$ V	-	52	165	-	205	-	250	ns
		$V_{CC} = 4.5$ V	-	19	33	-	41	-	50	ns
		$V_{CC} = 6.0$ V	-	15	28	-	35	-	43	ns
		$V_{CC} = 5.0$ V; $C_L = 15$ pF	-	16	-	-	-	-	-	ns
		\overline{PL} to Q7, $\overline{Q7}$; see Figure 8								
		$V_{CC} = 2.0$ V	-	50	165	-	205	-	250	ns
		$V_{CC} = 4.5$ V	-	18	33	-	41	-	50	ns
		$V_{CC} = 6.0$ V	-	14	28	-	35	-	43	ns
		$V_{CC} = 5.0$ V; $C_L = 15$ pF	-	15	-	-	-	-	-	ns
		D7 to Q7, $\overline{Q7}$; see Figure 9								
		$V_{CC} = 2.0$ V	-	36	120	-	150	-	180	ns
		$V_{CC} = 4.5$ V	-	13	24	-	30	-	36	ns
		$V_{CC} = 6.0$ V	-	10	20	-	26	-	31	ns
		$V_{CC} = 5.0$ V; $C_L = 15$ pF	-	11	-	-	-	-	-	ns
		t_t	transition time	Q7, $\overline{Q7}$ output; see Figure 7	[2]					
$V_{CC} = 2.0$ V	-			19	75	-	95	-	110	ns
$V_{CC} = 4.5$ V	-			7	15	-	19	-	22	ns
$V_{CC} = 6.0$ V	-			6	13	-	16	-	19	ns
t_w	pulse width	CP input HIGH or LOW; see Figure 7								
		$V_{CC} = 2.0$ V	80	17	-	100	-	120	-	ns
		$V_{CC} = 4.5$ V	16	6	-	20	-	24	-	ns
		$V_{CC} = 6.0$ V	14	5	-	17	-	20	-	ns
		\overline{PL} input LOW; see Figure 8								
		$V_{CC} = 2.0$ V	80	14	-	100	-	120	-	ns
		$V_{CC} = 4.5$ V	16	5	-	20	-	24	-	ns
		$V_{CC} = 6.0$ V	14	4	-	17	-	20	-	ns
		t_{rec}	recovery time	\overline{PL} to CP, \overline{CE} ; see Figure 8						
$V_{CC} = 2.0$ V	100			22	-	125	-	150	-	ns
$V_{CC} = 4.5$ V	20			8	-	25	-	30	-	ns
$V_{CC} = 6.0$ V	17			6	-	21	-	26	-	ns

Table 7. Dynamic characteristics ...continued
 GND (ground = 0 V); $C_L = 50 \text{ pF}$ unless otherwise specified; for test circuit, see [Figure 12](#)

Symbol	Parameter	Conditions	25 °C			-40 °C to +85 °C		-40 °C to +125 °C		Unit	
			Min	Typ	Max	Min	Max	Min	Max		
t_{su}	set-up time	DS to CP, \overline{CE} ; see Figure 10									
		$V_{CC} = 2.0 \text{ V}$	80	11	-	100	-	120	-	ns	
		$V_{CC} = 4.5 \text{ V}$	16	4	-	20	-	24	-	ns	
			$V_{CC} = 6.0 \text{ V}$	14	3	-	17	-	20	-	ns
			\overline{CE} to CP and CP to \overline{CE} ; see Figure 10								
			$V_{CC} = 2.0 \text{ V}$	80	17	-	100	-	120	-	ns
			$V_{CC} = 4.5 \text{ V}$	16	6	-	20	-	24	-	ns
			$V_{CC} = 6.0 \text{ V}$	14	5	-	17	-	20	-	ns
			Dn to \overline{PL} ; see Figure 11								
			$V_{CC} = 2.0 \text{ V}$	80	22	-	100	-	120	-	ns
			$V_{CC} = 4.5 \text{ V}$	16	8	-	20	-	24	-	ns
			$V_{CC} = 6.0 \text{ V}$	14	6	-	17	-	20	-	ns
t_h	hold time	DS to CP, \overline{CE} and Dn to \overline{PL} ; see Figure 10									
		$V_{CC} = 2.0 \text{ V}$	5	6	-	5	-	5	-	ns	
		$V_{CC} = 4.5 \text{ V}$	5	2	-	5	-	5	-	ns	
		$V_{CC} = 6.0 \text{ V}$	5	2	-	5	-	5	-	ns	
			\overline{CE} to CP and CP to \overline{CE} ; see Figure 10								
			$V_{CC} = 2.0 \text{ V}$	5	-17	-	5	-	5	-	ns
			$V_{CC} = 4.5 \text{ V}$	5	-6	-	5	-	5	-	ns
		$V_{CC} = 6.0 \text{ V}$	5	-5	-	5	-	5	-	ns	
f_{max}	maximum frequency	CP input; see Figure 7									
		$V_{CC} = 2.0 \text{ V}$	6	17	-	5	-	4	-	MHz	
		$V_{CC} = 4.5 \text{ V}$	30	51	-	24	-	20	-	MHz	
		$V_{CC} = 6.0 \text{ V}$	35	61	-	28	-	24	-	MHz	
		$V_{CC} = 5.0 \text{ V}$; $C_L = 15 \text{ pF}$	-	56	-	-	-	-	-	MHz	
C_{PD}	power dissipation capacitance	per package; $V_I = \text{GND to } V_{CC}$	[9]	-	35	-	-	-	-	pF	

Table 7. Dynamic characteristics ...continued
 GND (ground = 0 V); $C_L = 50$ pF unless otherwise specified; for test circuit, see [Figure 12](#)

Symbol	Parameter	Conditions	25 °C			-40 °C to +85 °C		-40 °C to +125 °C		Unit
			Min	Typ	Max	Min	Max	Min	Max	
74HCT165										
t_{pd}	propagation delay	\overline{CE} , CP to Q7, $\overline{Q7}$; see Figure 7 [1]								
		$V_{CC} = 4.5$ V	-	17	34	-	43	-	51	ns
		$V_{CC} = 5.0$ V; $C_L = 15$ pF	-	14	-	-	-	-	-	ns
		\overline{PL} to Q7, $\overline{Q7}$; see Figure 8								
		$V_{CC} = 4.5$ V	-	20	40	-	50	-	60	ns
		$V_{CC} = 5.0$ V; $C_L = 15$ pF	-	17	-	-	-	-	-	ns
		D7 to Q7, $\overline{Q7}$; see Figure 9								
		$V_{CC} = 4.5$ V	-	14	28	-	35	-	42	ns
		$V_{CC} = 5.0$ V; $C_L = 15$ pF	-	11	-	-	-	-	-	ns
t_t	transition time	Q7, $\overline{Q7}$ output; see Figure 7 [2]								
		$V_{CC} = 4.5$ V	-	7	15	-	19	-	22	ns
t_W	pulse width	CP input; see Figure 7								
		$V_{CC} = 4.5$ V	16	6	-	20	-	24	-	ns
		\overline{PL} input; see Figure 8								
		$V_{CC} = 4.5$ V	20	9	-	25	-	30	-	ns
t_{rec}	recovery time	\overline{PL} to CP, \overline{CE} ; see Figure 8								
		$V_{CC} = 4.5$ V	20	8	-	25	-	30	-	ns
t_{su}	set-up time	DS to CP, \overline{CE} ; see Figure 10								
		$V_{CC} = 4.5$ V	20	2	-	25	-	30	-	ns
		\overline{CE} to CP and CP to \overline{CE} ; see Figure 10								
		$V_{CC} = 4.5$ V	20	7	-	25	-	30	-	ns
		Dn to \overline{PL} ; see Figure 11								
		$V_{CC} = 4.5$ V	20	10	-	25	-	30	-	ns
t_h	hold time	DS to CP, \overline{CE} and Dn to \overline{PL} ; see Figure 10								
		$V_{CC} = 4.5$ V	7	-1	-	9	-	11	-	ns
		\overline{CE} to CP and CP to \overline{CE} ; see Figure 10								
		$V_{CC} = 4.5$ V	0	-7	-	0	-	0	-	ns
f_{max}	maximum frequency	CP input; see Figure 7								
		$V_{CC} = 4.5$ V	26	44	-	21	-	17	-	MHz
		$V_{CC} = 5.0$ V; $C_L = 15$ pF	-	48	-	-	-	-	-	MHz

Table 7. Dynamic characteristics ...continued

GND (ground = 0 V); $C_L = 50$ pF unless otherwise specified; for test circuit, see [Figure 12](#)

Symbol	Parameter	Conditions	25 °C			-40 °C to +85 °C		-40 °C to +125 °C		Unit
			Min	Typ	Max	Min	Max	Min	Max	
C_{PD}	power dissipation capacitance	per package; $V_I = GND$ to $V_{CC} - 1.5$ V	[3]	-	35	-	-	-	-	pF

[1] t_{pd} is the same as t_{PHL} and t_{PLH} .

[2] t_t is the same as t_{THL} and t_{TLH} .

[3] C_{PD} is used to determine the dynamic power dissipation (P_D in μ W).

$$P_D = C_{PD} \times V_{CC}^2 \times f_i + \sum (C_L \times V_{CC}^2 \times f_o) \text{ where:}$$

f_i = input frequency in MHz;

f_o = output frequency in MHz;

$\sum (C_L \times V_{CC}^2 \times f_o)$ = sum of outputs;

C_L = output load capacitance in pF;

V_{CC} = supply voltage in V.

12. Waveforms

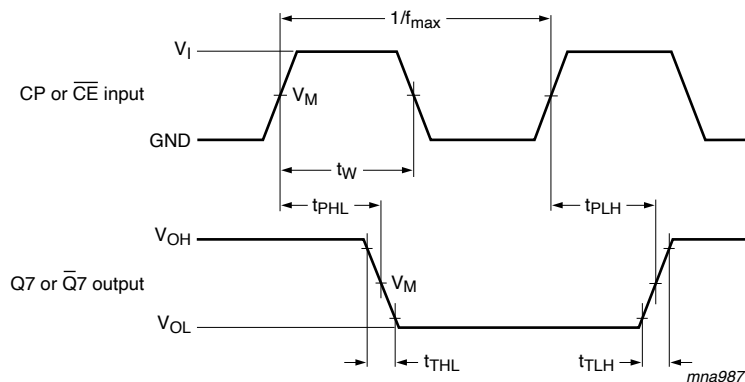

Measurement points are given in [Table 8](#).

V_{OL} and V_{OH} are typical voltage output levels that occur with the output load.

Fig 7. The clock (CP) or clock enable (\overline{CE}) to output (Q_7 or $\overline{Q_7}$) propagation delays, the clock pulse width, the maximum clock frequency and the output transition times

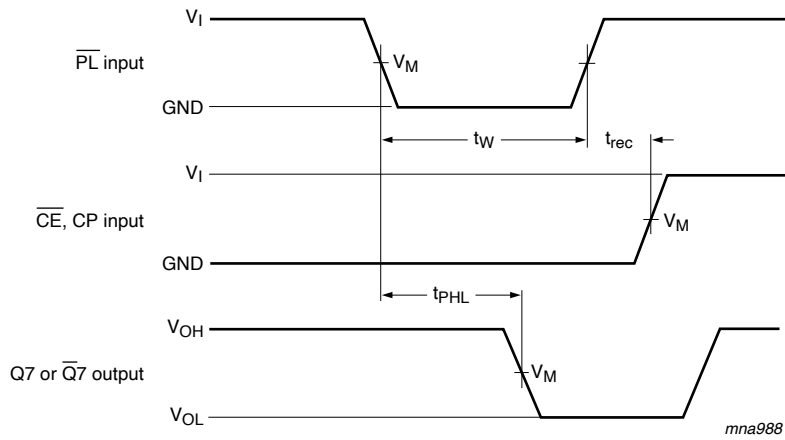

Measurement points are given in [Table 8](#).

V_{OL} and V_{OH} are typical voltage output levels that occur with the output load.

Fig 8. The parallel load (\overline{PL}) pulse width, the parallel load to output ($Q7$ or $\overline{Q7}$) propagation delays, the parallel load to clock (CP) and clock enable (\overline{CE}) recovery time

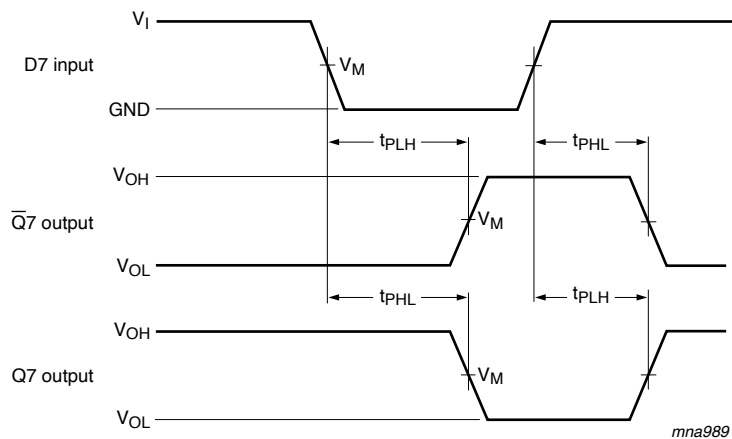

Measurement points are given in [Table 8](#).

V_{OL} and V_{OH} are typical voltage output levels that occur with the output load.

Fig 9. The data input ($D7$) to output ($Q7$ or $\overline{Q7}$) propagation delays when \overline{PL} is LOW

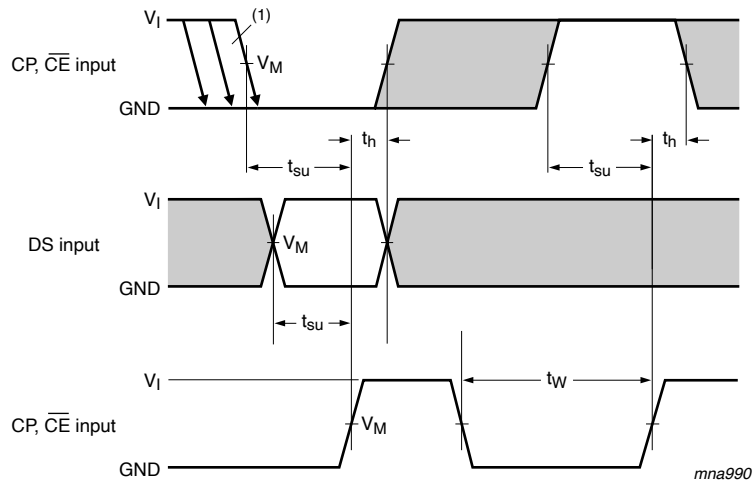

The shaded areas indicate when the input is permitted to change for predictable output performance. Measurement points are given in [Table 8](#).

V_{OL} and V_{OH} are typical voltage output levels that occur with the output load.

(1) \overline{CE} may change only from HIGH-to-LOW while CP is LOW, see [Section 1](#).

Fig 10. The set-up and hold times from the serial data input (DS) to the clock (CP) and clock enable (\overline{CE}) inputs, from the clock enable input (\overline{CE}) to the clock input (CP) and from the clock input (CP) to the clock enable input (\overline{CE})

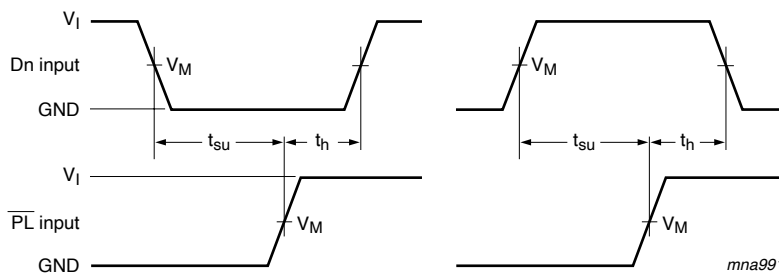

Measurement points are given in [Table 8](#).

V_{OL} and V_{OH} are typical voltage output levels that occur with the output load.

Fig 11. The set-up and hold times from the data inputs (Dn) to the parallel load input (\overline{PL})

Table 8. Measurement points

Type	Input		Output
	V_I	V_M	V_M
74HC165	V_{CC}	$0.5V_{CC}$	$0.5V_{CC}$
74HCT165	3 V	1.3 V	1.3 V

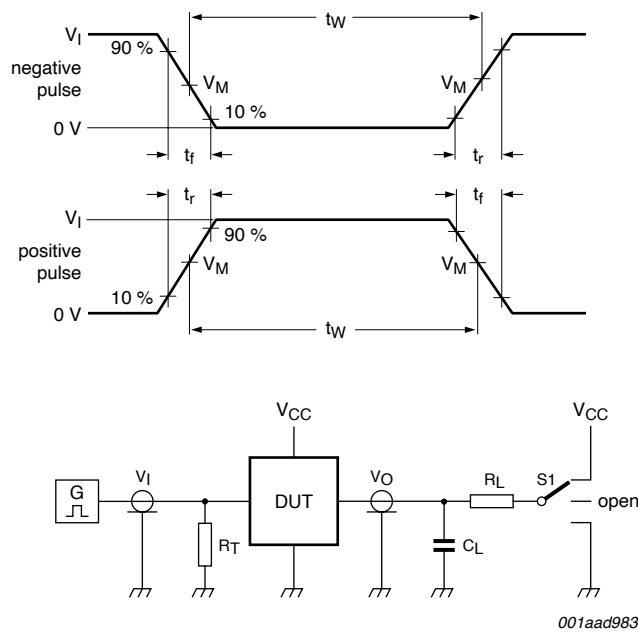

Test data is given in [Table 9](#).

Definitions for test circuit:

R_T = Termination resistance should be equal to output impedance Z_o of the pulse generator.

C_L = Load capacitance including jig and probe capacitance.

R_L = Load resistance.

S1 = Test selection switch

Fig 12. Test circuit for measuring switching times

Table 9. Test data

Type	Input		Load			S1 position
	V_I	t_r, t_f	C_L	R_L	t_{PHL}, t_{PLH}	
74HC165	V_{CC}	6 ns	15 pF, 50 pF	1 k Ω	open	
74HCT165	3 V	6 ns	15 pF, 50 pF	1 k Ω	open	

13. Package outline

DIP16: plastic dual in-line package; 16 leads (300 mil)

SOT38-4

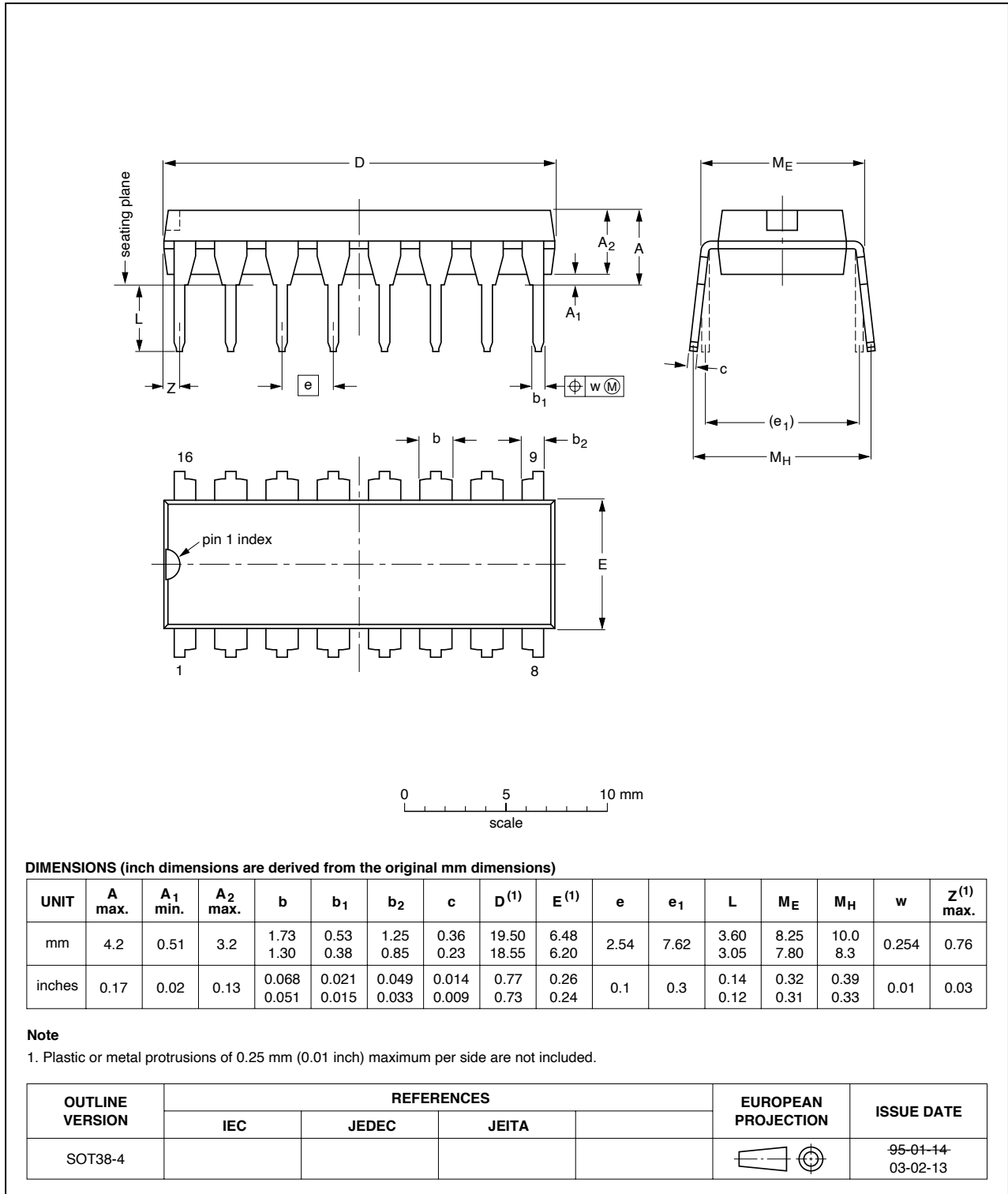

Fig 13. Package outline SOT38-4 (DIP16)

SO16: plastic small outline package; 16 leads; body width 3.9 mm

SOT109-1

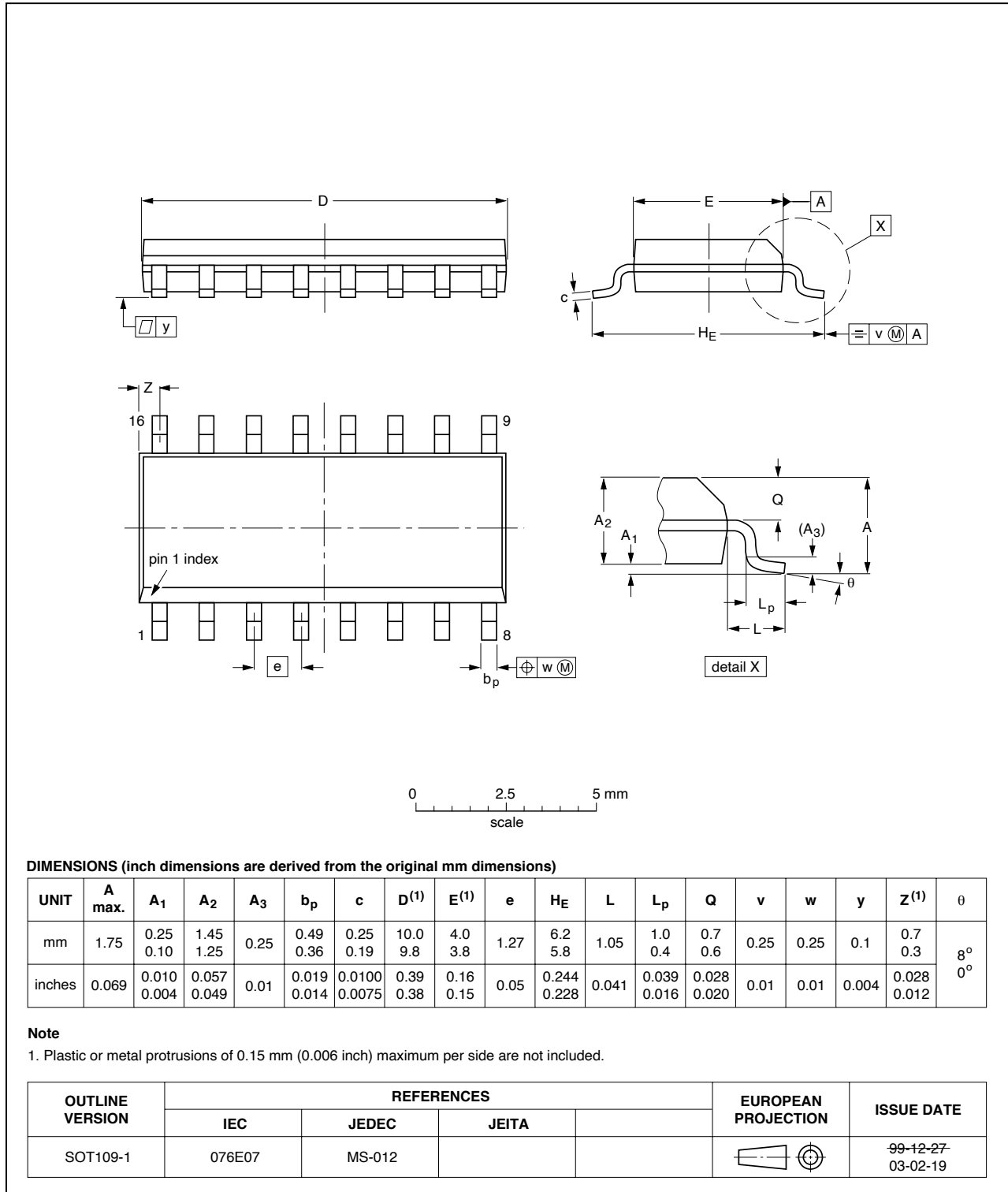

Fig 14. Package outline SOT109-1 (SO16)

SSOP16: plastic shrink small outline package; 16 leads; body width 5.3 mm

SOT338-1

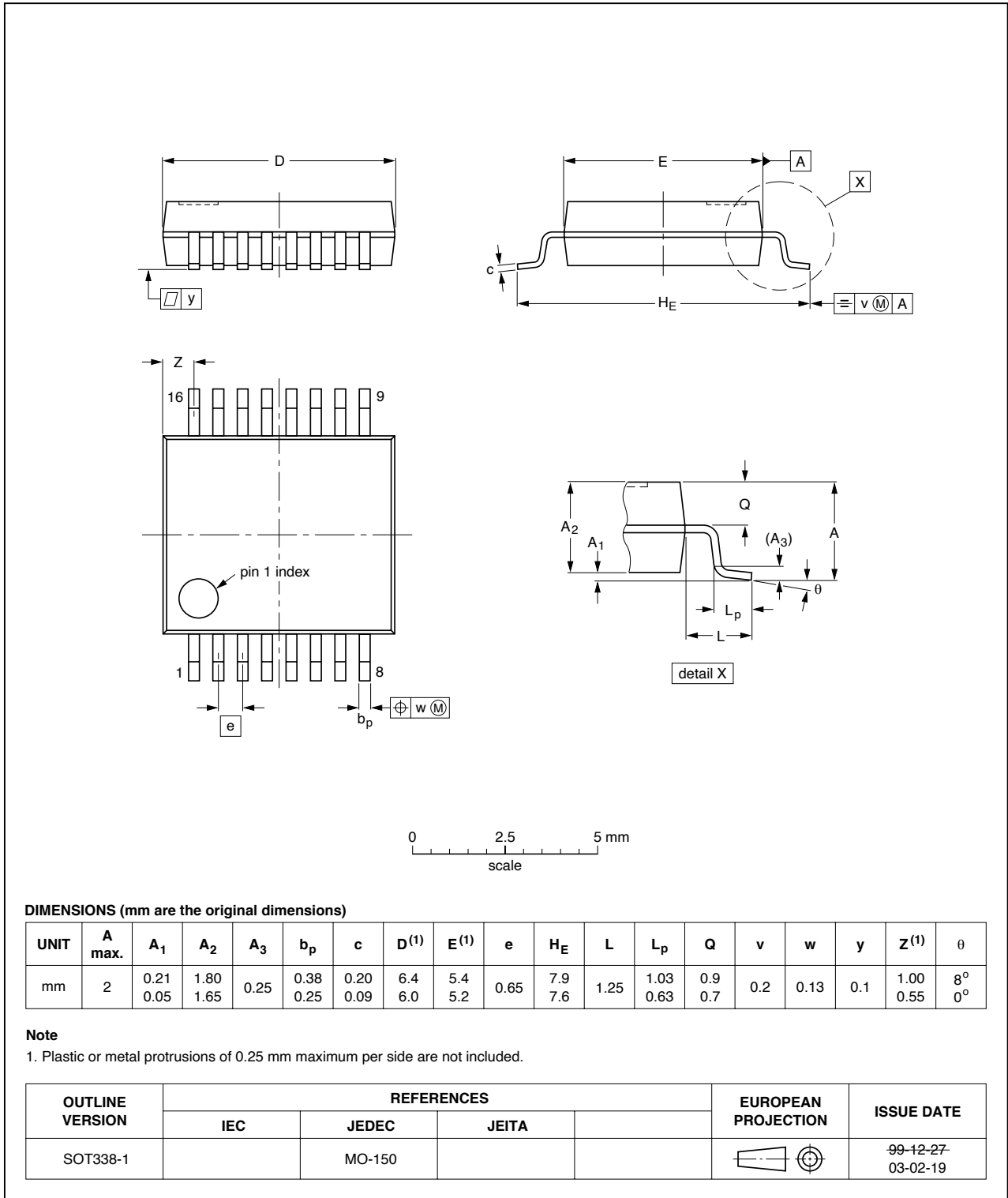

Fig 15. Package outline SOT338-1 (SSOP16)

TSSOP16: plastic thin shrink small outline package; 16 leads; body width 4.4 mm

SOT403-1

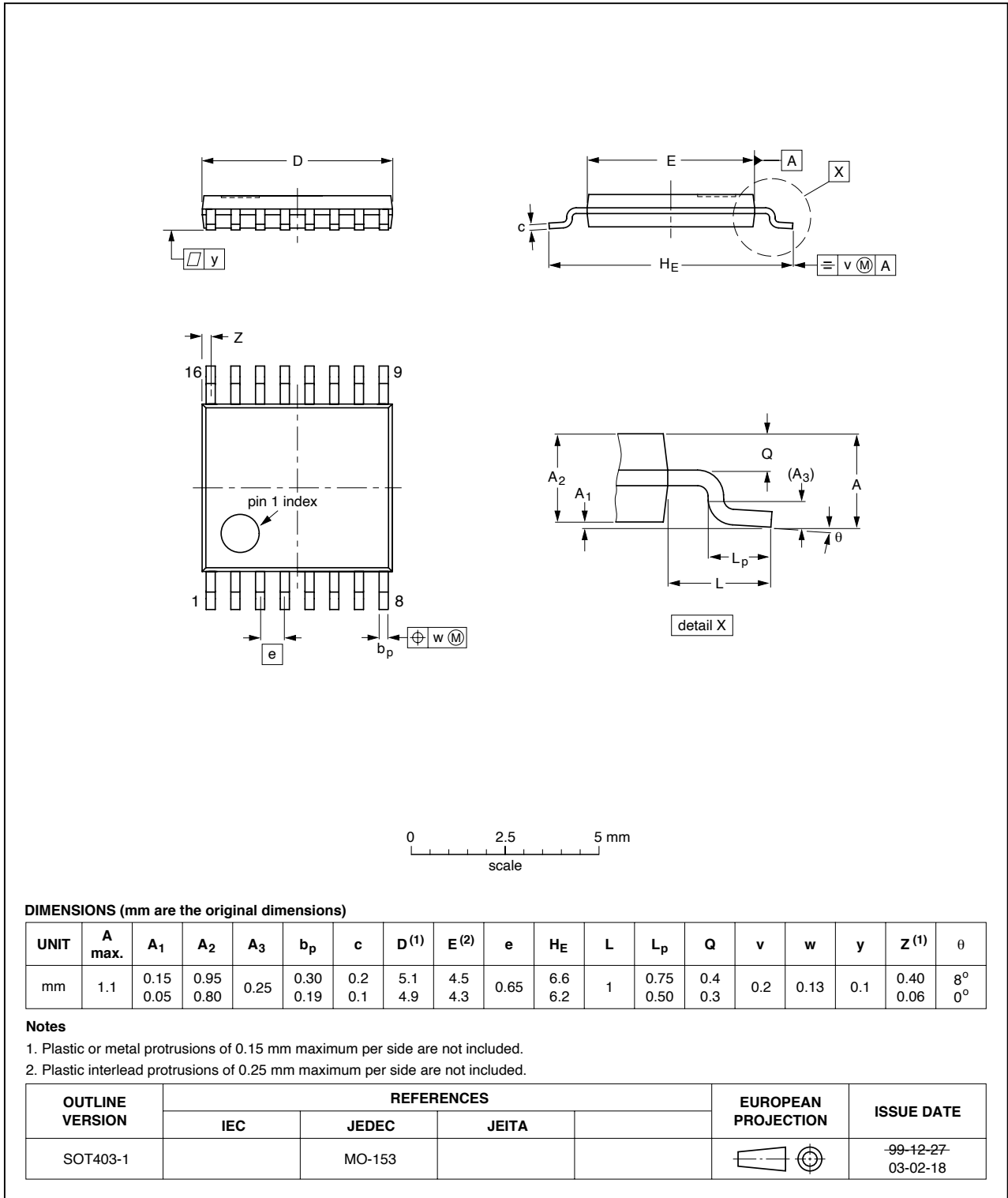

Fig 16. Package outline SOT403-1 (TSSOP16)

DHVQFN16: plastic dual in-line compatible thermal enhanced very thin quad flat package; no leads; 16 terminals; body 2.5 x 3.5 x 0.85 mm

SOT763-1

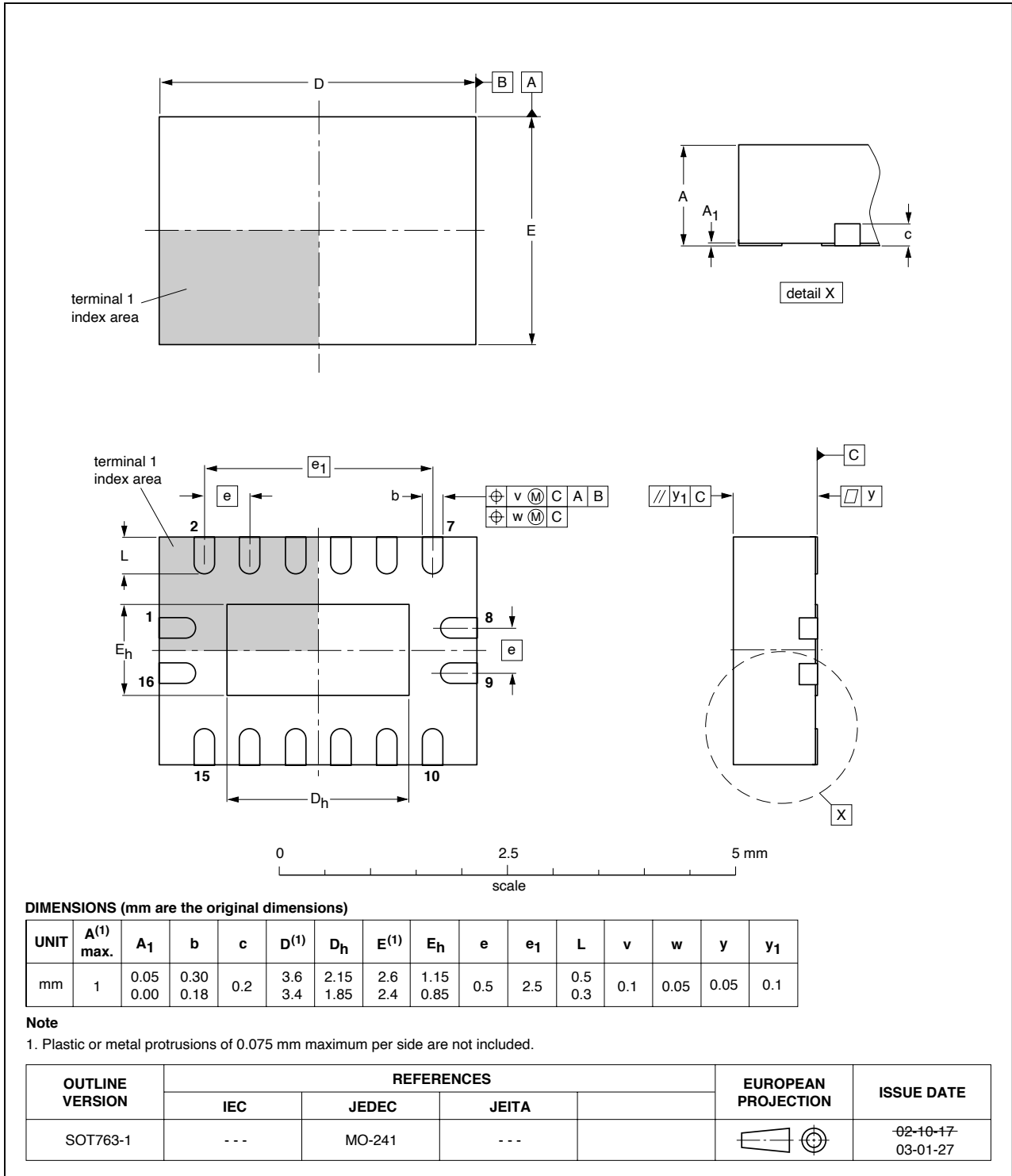

Fig 17. Package outline SOT763-1 (DHVQFN16)

14. Abbreviations

Table 10. Abbreviations

Acronym	Description
CMOS	Complementary Metal-Oxide Semiconductor
DUT	Device Under Test
ESD	ElectroStatic Discharge
HBM	Human Body Model
MM	Machine Model
TTL	Transistor-Transistor Logic

15. Revision history

Table 11. Revision history

Document ID	Release date	Data sheet status	Change notice	Supersedes
74HC_HCT165_3	20080314	Product data sheet	-	74HC_HCT165_CNV_2
Modifications:	<ul style="list-style-type: none"> The format of this data sheet has been redesigned to comply with the new identity guidelines of NXP Semiconductors. Legal texts have been adapted to the new company name where appropriate. Package SOT763-1 (DHVQFN16) added to Section 4 “Ordering information” and Section 13 “Package outline”. Family data added, see Section 10 “Static characteristics” 			
74HC_HCT165_CNV_2	December 1990	Product specification	-	-

16. Legal information

16.1 Data sheet status

Document status ^{[1][2]}	Product status ^[3]	Definition
Objective [short] data sheet	Development	This document contains data from the objective specification for product development.
Preliminary [short] data sheet	Qualification	This document contains data from the preliminary specification.
Product [short] data sheet	Production	This document contains the product specification.

[1] Please consult the most recently issued document before initiating or completing a design.

[2] The term 'short data sheet' is explained in section "Definitions".

[3] The product status of device(s) described in this document may have changed since this document was published and may differ in case of multiple devices. The latest product status information is available on the Internet at URL <http://www.nxp.com>.

16.2 Definitions

Draft — The document is a draft version only. The content is still under internal review and subject to formal approval, which may result in modifications or additions. NXP Semiconductors does not give any representations or warranties as to the accuracy or completeness of information included herein and shall have no liability for the consequences of use of such information.

Short data sheet — A short data sheet is an extract from a full data sheet with the same product type number(s) and title. A short data sheet is intended for quick reference only and should not be relied upon to contain detailed and full information. For detailed and full information see the relevant full data sheet, which is available on request via the local NXP Semiconductors sales office. In case of any inconsistency or conflict with the short data sheet, the full data sheet shall prevail.

16.3 Disclaimers

General — Information in this document is believed to be accurate and reliable. However, NXP Semiconductors does not give any representations or warranties, expressed or implied, as to the accuracy or completeness of such information and shall have no liability for the consequences of use of such information.

Right to make changes — NXP Semiconductors reserves the right to make changes to information published in this document, including without limitation specifications and product descriptions, at any time and without notice. This document supersedes and replaces all information supplied prior to the publication hereof.

Suitability for use — NXP Semiconductors products are not designed, authorized or warranted to be suitable for use in medical, military, aircraft, space or life support equipment, nor in applications where failure or

malfunction of an NXP Semiconductors product can reasonably be expected to result in personal injury, death or severe property or environmental damage. NXP Semiconductors accepts no liability for inclusion and/or use of NXP Semiconductors products in such equipment or applications and therefore such inclusion and/or use is at the customer's own risk.

Applications — Applications that are described herein for any of these products are for illustrative purposes only. NXP Semiconductors makes no representation or warranty that such applications will be suitable for the specified use without further testing or modification.

Limiting values — Stress above one or more limiting values (as defined in the Absolute Maximum Ratings System of IEC 60134) may cause permanent damage to the device. Limiting values are stress ratings only and operation of the device at these or any other conditions above those given in the Characteristics sections of this document is not implied. Exposure to limiting values for extended periods may affect device reliability.

Terms and conditions of sale — NXP Semiconductors products are sold subject to the general terms and conditions of commercial sale, as published at <http://www.nxp.com/profile/terms>, including those pertaining to warranty, intellectual property rights infringement and limitation of liability, unless explicitly otherwise agreed to in writing by NXP Semiconductors. In case of any inconsistency or conflict between information in this document and such terms and conditions, the latter will prevail.

No offer to sell or license — Nothing in this document may be interpreted or construed as an offer to sell products that is open for acceptance or the grant, conveyance or implication of any license under any copyrights, patents or other industrial or intellectual property rights.

16.4 Trademarks

Notice: All referenced brands, product names, service names and trademarks are the property of their respective owners.

17. Contact information

For more information, please visit: <http://www.nxp.com>

For sales office addresses, please send an email to: salesaddresses@nxp.com

18. Contents

1	General description	1
2	Features	1
3	Applications	1
4	Ordering information	2
5	Functional diagram	2
6	Pinning information	3
6.1	Pinning	3
6.2	Pin description	4
7	Functional description	4
8	Limiting values	5
9	Recommended operating conditions	6
10	Static characteristics	6
11	Dynamic characteristics	8
12	Waveforms	11
13	Package outline	15
14	Abbreviations	20
15	Revision history	20
16	Legal information	21
16.1	Data sheet status	21
16.2	Definitions	21
16.3	Disclaimers	21
16.4	Trademarks	21
17	Contact information	21
18	Contents	22

Please be aware that important notices concerning this document and the product(s) described herein, have been included in section 'Legal information'.



© NXP B.V. 2008.

All rights reserved.

For more information, please visit: <http://www.nxp.com>

For sales office addresses, please send an email to: salesaddresses@nxp.com

Date of release: 14 March 2008

Document identifier: 74HC_HCT165_3